

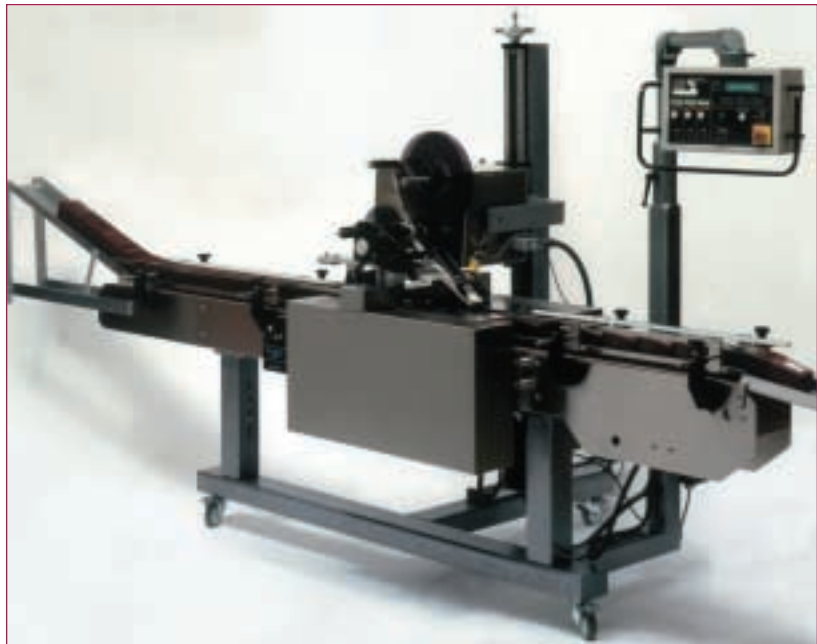

Top Apply Automatic Label Applicator System



- Compatible with all ID Technology label applicators.
- Capable of running at speeds up to 3100 linear inches per minute (depending on label applicator selection).
- Heavy-duty construction designed for industrial applications.
- Stainless steel and anodized aluminum provide protection from corrosive environments.
- Solid construction ensures even product handling resulting in extremely accurate label placement.
- Fully adjustable I/O mounts permit the applicator head to be oriented to any attitude for side, top or bottom label placement.
- Handles a wide assortment of product and label sizes.

Standard wipe-on systems come complete with an 8' by 6" chain link conveyor, a single applicator head I/O mount, a microprocessor controller hung from an articulator arm, guide rails, and a spacer wheel assembly. The conveyor height is fully adjustable between 32 and 39 inches and capable of handling products up to 6" wide. Each conveyor system includes heavy-duty construction, robust locking casters, vertical, horizontal and swivel adjustments for applicator head mounting and a heavy-duty 1/4 horsepower adjustable speed motor.

Top Apply Automatic Label Applicator System

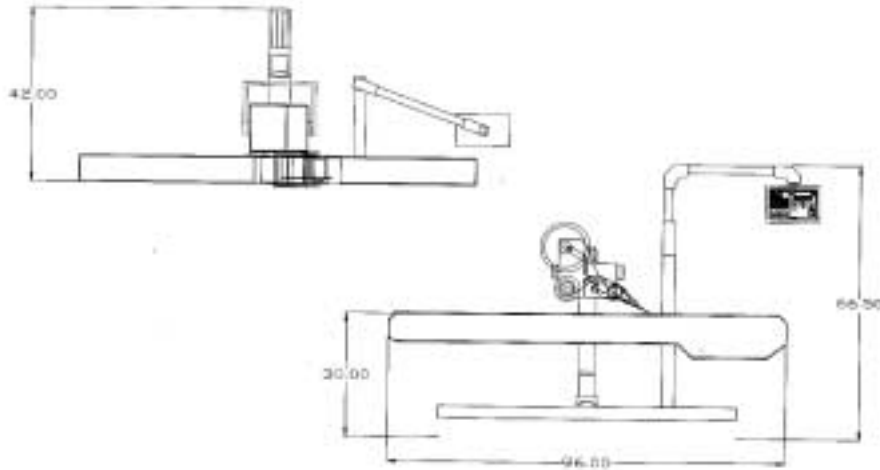

Note: All photography and dimensional drawings depict representative examples of systems. Dimensions, options and controls vary by application.

Applicator System Specifications

| | |
|----------------------------|--|
| Speed | Up to 3100 linear inches per minute |
| Accuracy | ±1/32" with consistent product dimensions |
| Control Electronics | Microprocessor controller |
| Label Size | Minimum: 0.5" by 0.5" Maximum: 6.5" by 18" |
| Electrical | 110 VAC, 50/60 Hertz, 15 Amps |
| Product Detection | Photoelectric |
| Label Capacity | 6.5" Web Width, 12"/ 16"/ 18" diameter label roll capacity with a 3" core |
| Options | Stainless Steel Base Stainless Steel Wash Down Optional Wrap Station 3 / 4 / 5 Panel Station Powered Top Hold Down Optional Conveyor Lengths and Widths Dual Powered Alignment Belts Error / Warning Light Pole Secondary Impression Kit Custom Product Handling Gap Transporter Belts |



2051 Franklin Dr.
Fort Worth, TX 76106
888.438.3242
www.idtechnology.com

TECHNOLOGY